



**19SEER
5ton Inverter Rooftop Preview**

Rooftop Application



Horizontal Application

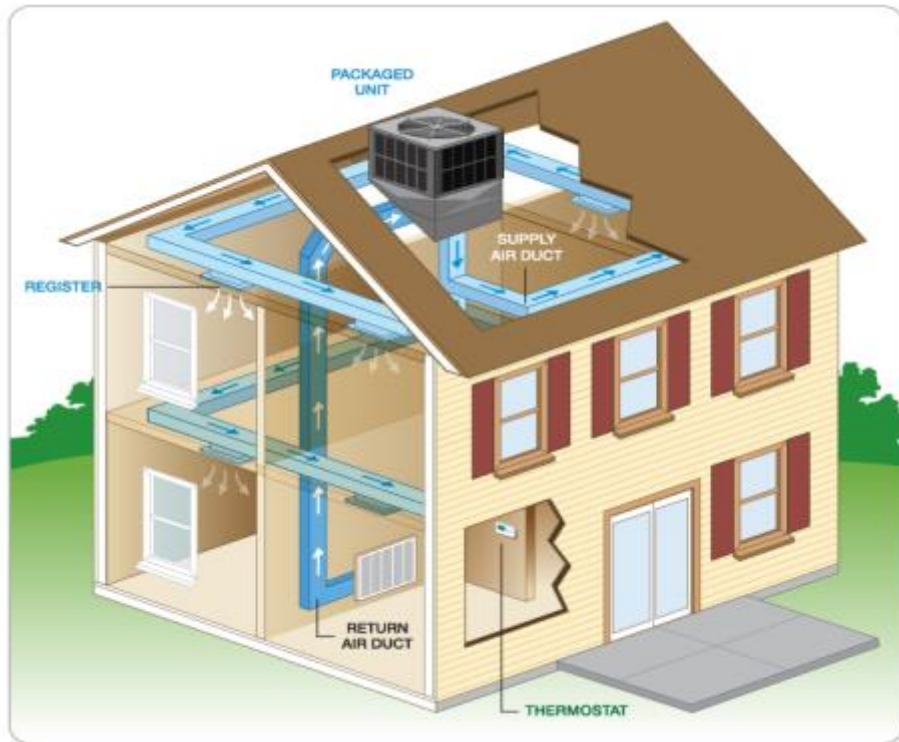

Down flow Application

Features overview

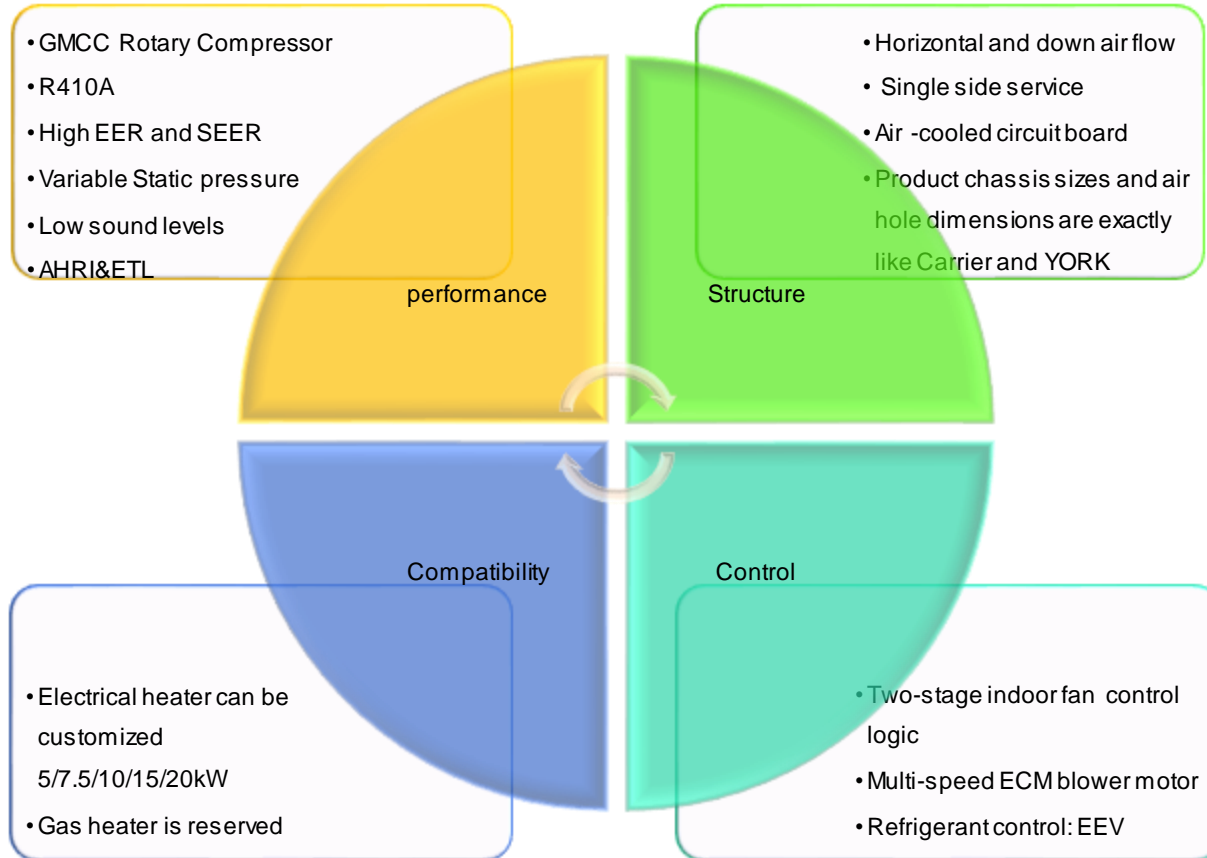

GMCC High Efficiency Rotary Compressor

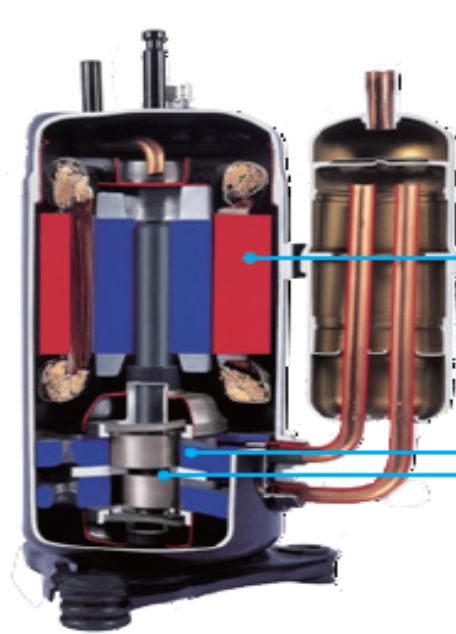

Compressor
(Twin Rotary) structure

Highly Efficient DC Motor:

- Creative motor core design
- High density neodymium magnet
- Concentrated type stator
- Wider operating frequency range

Better balance and Extremely Low Vibration:

- Twin eccentric cams
- 2 balance weights

Highly Stable Moving Parts:

- Optimal material matching rollers and vanes
- Optimize compressor drive technology
- Highly robust bearings
- Compact structure

Detailed Features

1) Capacity: 57000Btu/h SEER ≥19, EER ≥12.5; HSPF ≥8.5; Beyond the standard of Energy star (best level in USA: SEER=16, EER=12.5)

2) Two speed blower, switch automatically (none communication between indoor and outdoor, newest tech among competitors)

3) All DC inverted, whole new air-cool tech for boards, 26% performance improvement on cooling in high temp, and increase of reliability at the same time

8) Sheet metal Self compression of Glass fiber cotton in inner duct. Simple operate for producing and impossible for cotton to drop



9) Comp and EXV—self learning, control more precisely, more comfort, more efficiency

5) Large outdoor fin with diameter of 650mm, 1.5dB decrease compared with main competitors in same rotate speed.

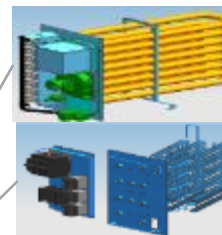
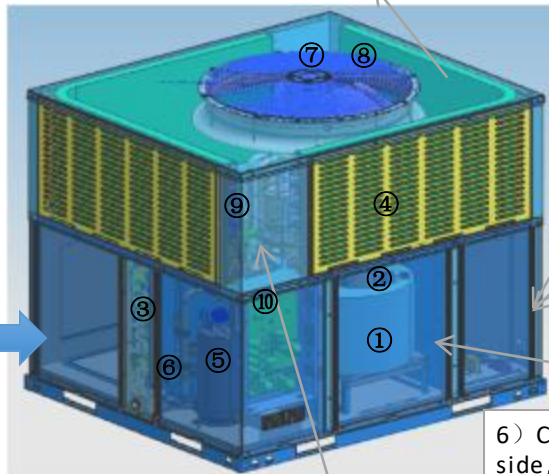

4) Modularization design, Gas module and EH can be installed in field

6) Comp, PCB, blower, EH, Gas module are designed in one side, all can be reached in one side. Very easy service

7) Bridging tech for cooling fin of PCB boards, much more convenient for boards replacing

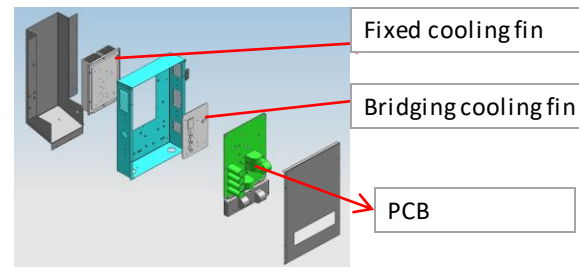

①	Indoor blower	⑥	EXV
②	Indoor motor	⑦	Outdoor motor
③	EVP	⑧	Outdoor Fin
④	COD	⑨	RV
⑤	Comp	⑩	PCB

Detailed Features



Convenient pressure measure access.

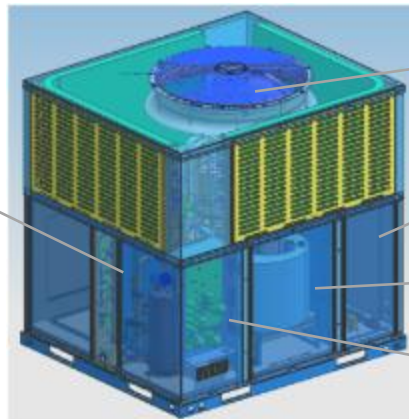

DC fan motor with 10 speed

EH and Gas module can be switched by your will

Pathway design for indoor blower, easy tear down

Hinge design for boards, can be rotate out for reaching compressor

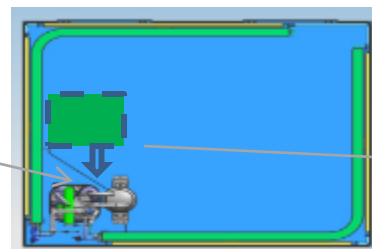
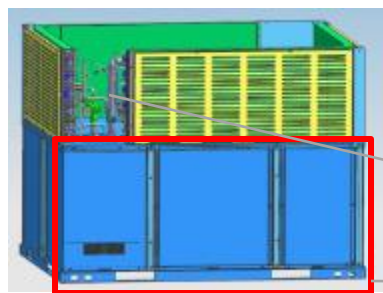
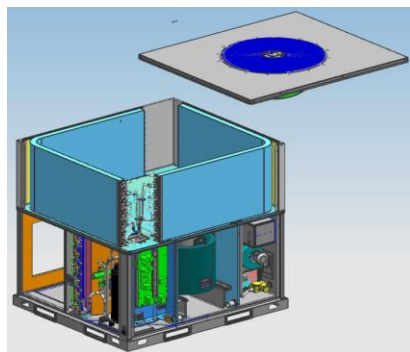

RV is moved to side from center, we can reach to RV without moving tectum

One side service access for all major parts

Size comparison



Brand	Tons	W	D	H	Model No.#	EER	SEER	Comments
Carrier	2	48-3/16"	32-5/8"	51-3/4	50VR-C24	12	15	2 Chassis with 4 heights
	2.5	48-3/16"	32-5/8"	51-3/4	50VR-C30	12	15	
	3	48-1/4	44-3/16	44-3/4	50VG-A36	12	15	
	3.5	48-1/4	44-3/16	50-3/4	50VG-A42	12	15	
	4	48-1/4	44-3/16	48-3/4	50VG-A48	12.5	15.5	
	5	48-1/4	44-3/16	54-3/4	50VG-A60	12	15	
YORK	2	51-1/4	35-3/4	47	PHE6A2421	12.5	16	2 Chassis with 4 heights
	2.5	51-1/4	35-3/4	47	PHE6A3021	12.5	16	
	3	51-1/4	45-3/4	49	PHE6B3621	12.5	16	
	3.5	51-1/4	45-3/4	49	PHE6B4221	12.5	16	
	4	51-1/4	45-3/4	53	PHE6B4821	12.5	16	
	5	51-1/4	45-3/4	55	PHE6B6021	12.5	16	
Trane-16 SEER	2	45	52	48	4WCZ6024*	12	16	3 Chassis with 2 heights With fork hole will be increased 120mm
	3	51	43	38	4WCZ6036*	12.2	16	
	4	61	46	42	4WCZ6048*	12	16	
	5	61	46	42	4WCZ6060*	11.5	15	
Trane-15SEER	2	50-3/4"	47	36	4WCY5024*	13	15	2 Chassis with 4 heights With fork hole will be increased 120mm
	2.5	50-3/4"	47	37-1/4"	4WCY5030*	12	15	
	3	50-3/4"	47	37-1/4"	4WCY5036*	12	15	
	3.5	50-3/4"	46	41-1/4"	4WCY5042*	12	15	
	4	60-1/4"	46	41-1/4"	4WCY5048*	12	15	
	5	60-1/4"	46	41-1/4"	4WCY5060*	11.5	15	
Goodman	2	47	51	34-3/4	GPH1624M41A*	12.5	16	1 Chassis with 2 heights
	2.5	47	51	34-3/4	GPH1630M41A*	12	15.5	
	3	47	51	34-3/4	GPH1636M41A*	12	16	
	3.5	47	51	34-3/4	GPH1642M41A*	12	16	
	4	47	51	42-1/4	GPH1648M41A*	12	16	
	5	47	51	42-1/4	GPH1660M41A*	12	16	
Midea	2-3Ton	51-9/16	35-3/4"	48-5/8"	N/A			2 Chassis with 2 heights
	4-5Ton	51-9/16	44-7/8	52	N/A			
Rheem	2	59	33	29 1/8	RQRMA024JK	13	16	Horizontal Only
	2.5	59	33	37 1/8"	RQRMA030JK	13	16	
	3	59	33	37 1/8"	RQRMA036JK	13	16	
	3.5	59	33	37 1/8"	RQRMA042JK	13	16	
	4	59	33	37 1/8"	RQRMA048JK	13	16	
	5	59	33	37 1/8"	RQRMA060JK	12	15	

Structure and Dimension

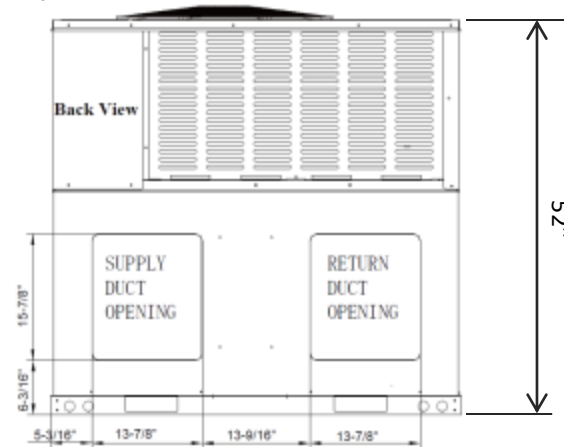
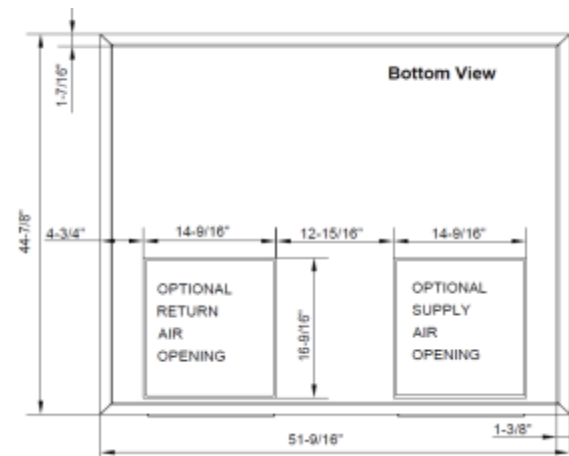
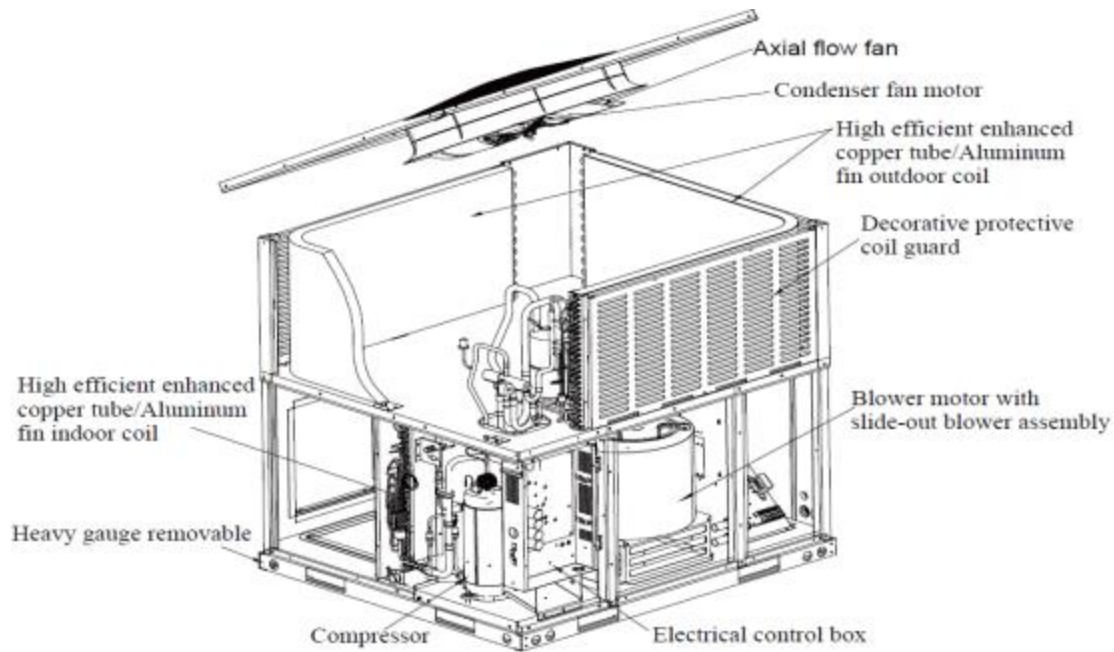

5Ton UNIT	SUPPLY AIR Duct		RETURN AIR Duct	
	LENGTH (IN)	WIDTH (IN)	LENGTH (IN)	WIDTH (IN)
HORIZONTAL	15-15/16"	13-15/16"	15-15/16"	13-15/16"
DOWN FLOW	16-9/16"	14-9/16"	16-9/16"	14-9/16"

Electrical Parts

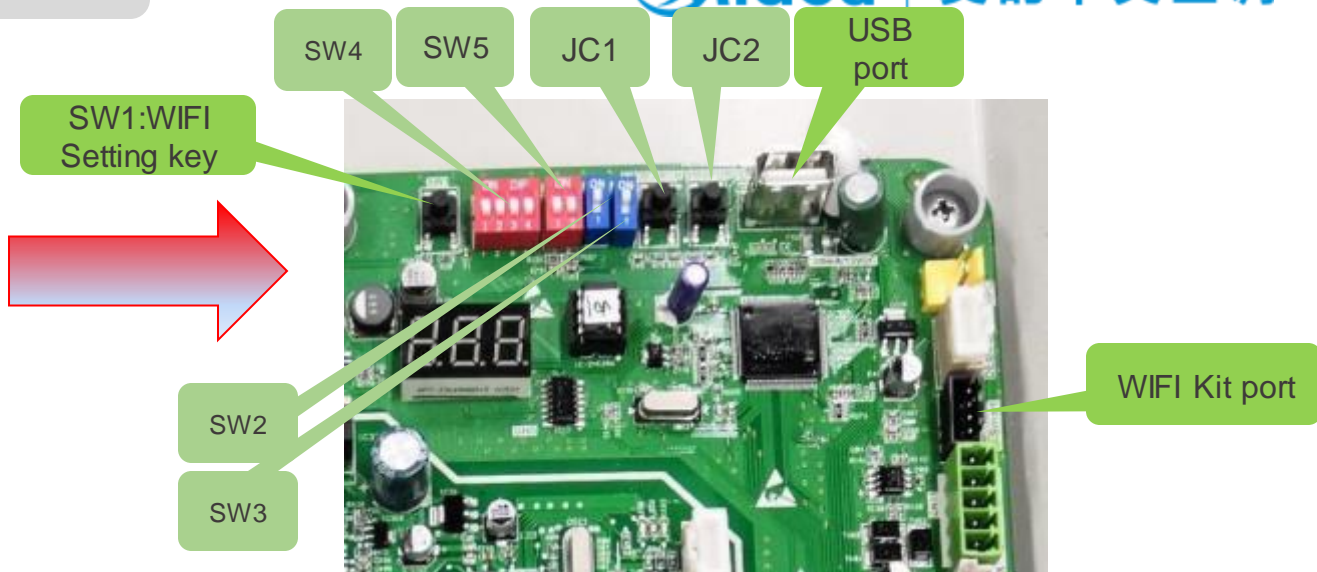
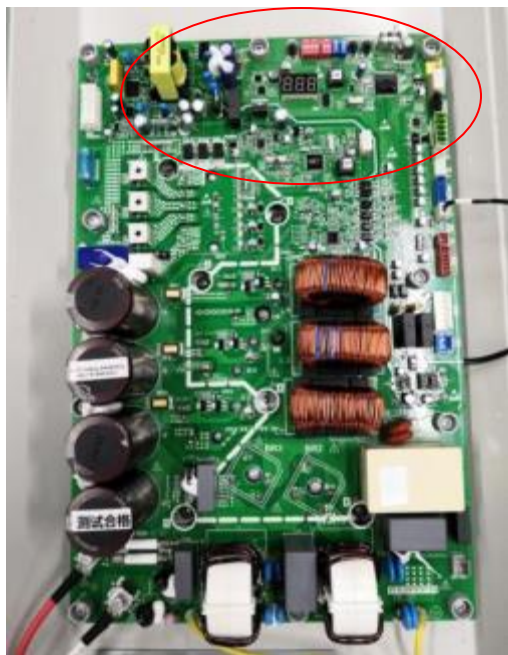

- SW1 + port for WIFI kit connect and setting
- SW2+SW3 button for check data/force mode/testing mode/manual defrost.
- SW4-1 + JC1 + JC2 for model setting
- SW4-2/3/4 for capacity requirement setting
- SW5 for defrost setting

Electrical Parts

Switch	Position	Function
SW1		For wifi settings
SW2&3		For check data/force mode/testing mode/manual defrost
SW4-1	ON	Program For rooftop package
	OFF	Program For IDS
SW4-2		Not used
SW4-3	ON	Adaptive capacity output disabled
	OFF	Adaptive capacity output enabled
SW4-4	ON	Accelerated cooling/heating
	OFF	Normally cooling/heating
SW5-1	ON	Operating time is reduced by 10%
	OFF	Normal
SW5-2	ON	Defrosting extended for 60 seconds
	OFF	Normal
JC1	ON	Heat pump
	OFF	Cooling only
JC2	ON	For 3/5ton Capacity(default setting)
	OFF	For 2/4ton Capacity

Defrost Control Logic

- ▶ The Demand Defrost Control (DDC) monitors the ODU coil temperature using thermistor (T3). A second thermistor (T4) monitors outdoor ambient temperature. Based on these parameters, as well as accumulative run time and high pressure, the DDC calculates proper initiation of defrost.
- ▶ Any one of the three conditions is required to enter defrost:
 1. The calculated temperature difference between the outdoor temperature (T4) and the coil temperature (T3) is called Delta T. After Delta T is achieved and continues for 3 minutes.
 - $T4 \geq 39^{\circ}\text{F}$, $\Delta T = 18^{\circ}\text{F}$
 - $T4 \geq 30^{\circ}\text{F}$, $\Delta T = 16^{\circ}\text{F}$
 - $T4 \geq 19^{\circ}\text{F}$, $\Delta T = 14^{\circ}\text{F}$
 - When $T4 < 19^{\circ}\text{F}$, $T3 < 9^{\circ}\text{F}$, accumulative compressor run time ≥ 80 minutes.
 2. After "Minimum Run Time" (MRT) is achieved. MRT is based on outdoor ambient temperature (T4), for example:
 - MRT is 4 hours when: $T4 < 23^{\circ}\text{F}$
 - MRT is 2 hours when: $23^{\circ}\text{F} \leq T4 < 42^{\circ}\text{F}$
 3. After the high pressure saturation temperature drops below 82°F for 20 minutes.

- ▶ Defrost will terminate once outdoor coil temperature (T3) reaches 64°F for a period of 1 minute or defrost time has exceeded 8 minutes.
- ▶ Defrost Termination Settings (SW5) offers different defrost termination options for enhanced defrost for different geographical and outdoor conditions.

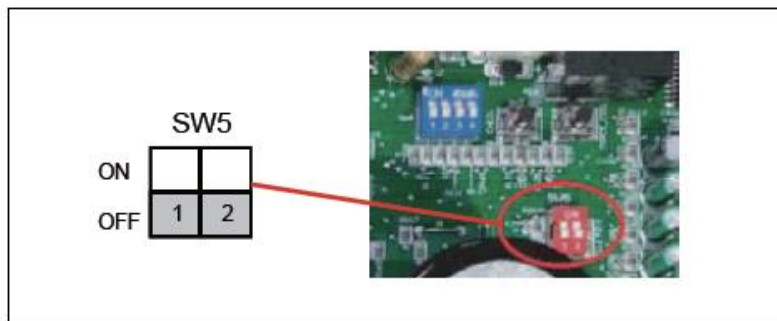
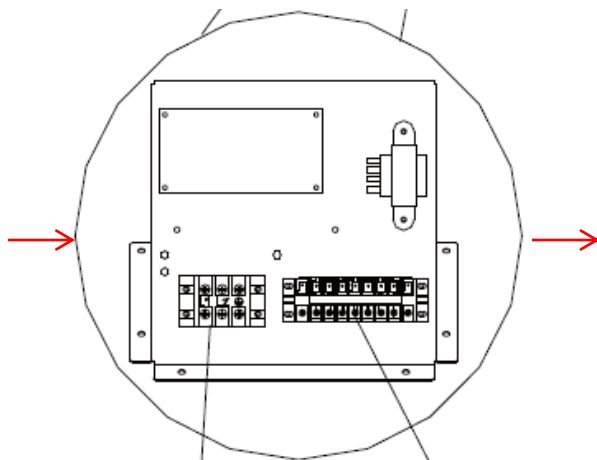
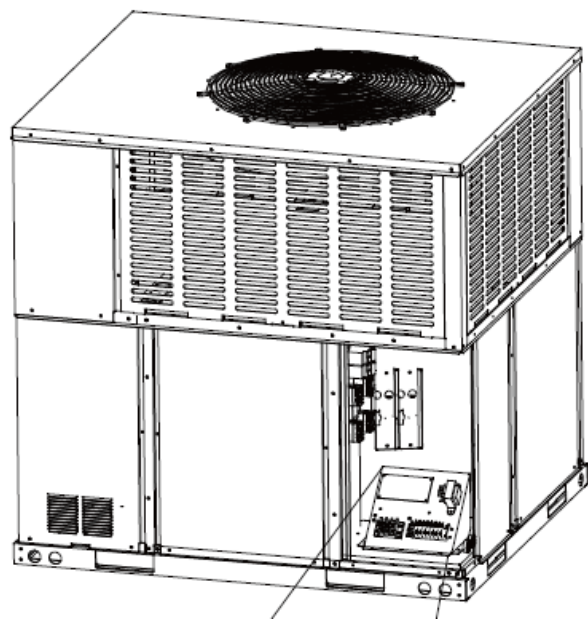

Figure 9-2

Defrosting Choice	SW5-1	SW5-2	Remarks
ON	Operating time is reduced by 10%	Defrosting extended for 60 seconds	
OFF	Normal	Normal	Default
Remarks	Enter defrost	Quit defrost	

24V Control Wiring



High voltage power supply Control wiring

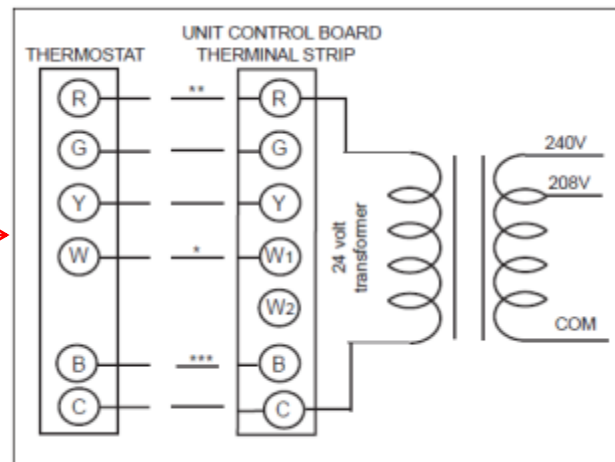

Two Speed Indoor Blower Control



DIP Switch:
1&2 select model, 3, Select anti-cold wind,
4, reservation

Introduction

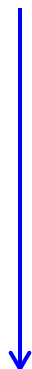

A	ON	<input type="checkbox"/>	<input type="checkbox"/>	<input type="checkbox"/>	<input type="checkbox"/>	Non Factory setting (For A type) : 1=OFF, 2=OFF (00) Fan speed: Y2/Y1 corresponding to 2/1 level speed.
	OFF	<input checked="" type="checkbox"/>	<input checked="" type="checkbox"/>	<input type="checkbox"/>	<input type="checkbox"/>	
B	ON	<input type="checkbox"/>	<input checked="" type="checkbox"/>	<input type="checkbox"/>	<input type="checkbox"/>	Factory setting (For B type) : 1=OFF, 2=ON (01) Fan speed: Y2/Y1 corresponding to 3/1 level speed.
	OFF	<input checked="" type="checkbox"/>	<input type="checkbox"/>	<input type="checkbox"/>	<input type="checkbox"/>	
C	ON	<input checked="" type="checkbox"/>	<input type="checkbox"/>	<input type="checkbox"/>	<input type="checkbox"/>	Factory setting (For C type) : 1=ON, 2=OFF (10) Fan speed: Y2/Y1 corresponding to 4/2 level speed.
	OFF	<input type="checkbox"/>	<input checked="" type="checkbox"/>	<input type="checkbox"/>	<input type="checkbox"/>	
D	ON	<input checked="" type="checkbox"/>	<input checked="" type="checkbox"/>	<input type="checkbox"/>	<input type="checkbox"/>	Non Factory setting (For D type) : 1=ON, 2=ON (11) Fan speed: Y2/Y1 corresponding to 5/3 level speed.
	OFF	<input type="checkbox"/>	<input type="checkbox"/>	<input checked="" type="checkbox"/>	<input checked="" type="checkbox"/>	

4T
2T/3T/5T

防冷风设置介绍



3=ON, Anti-cold wind Valid/ **制热风机防冷风控制**
3=OFF, Anti-cold wind invalid / **制热风机固定延迟启动90秒。**

System Pipe Design

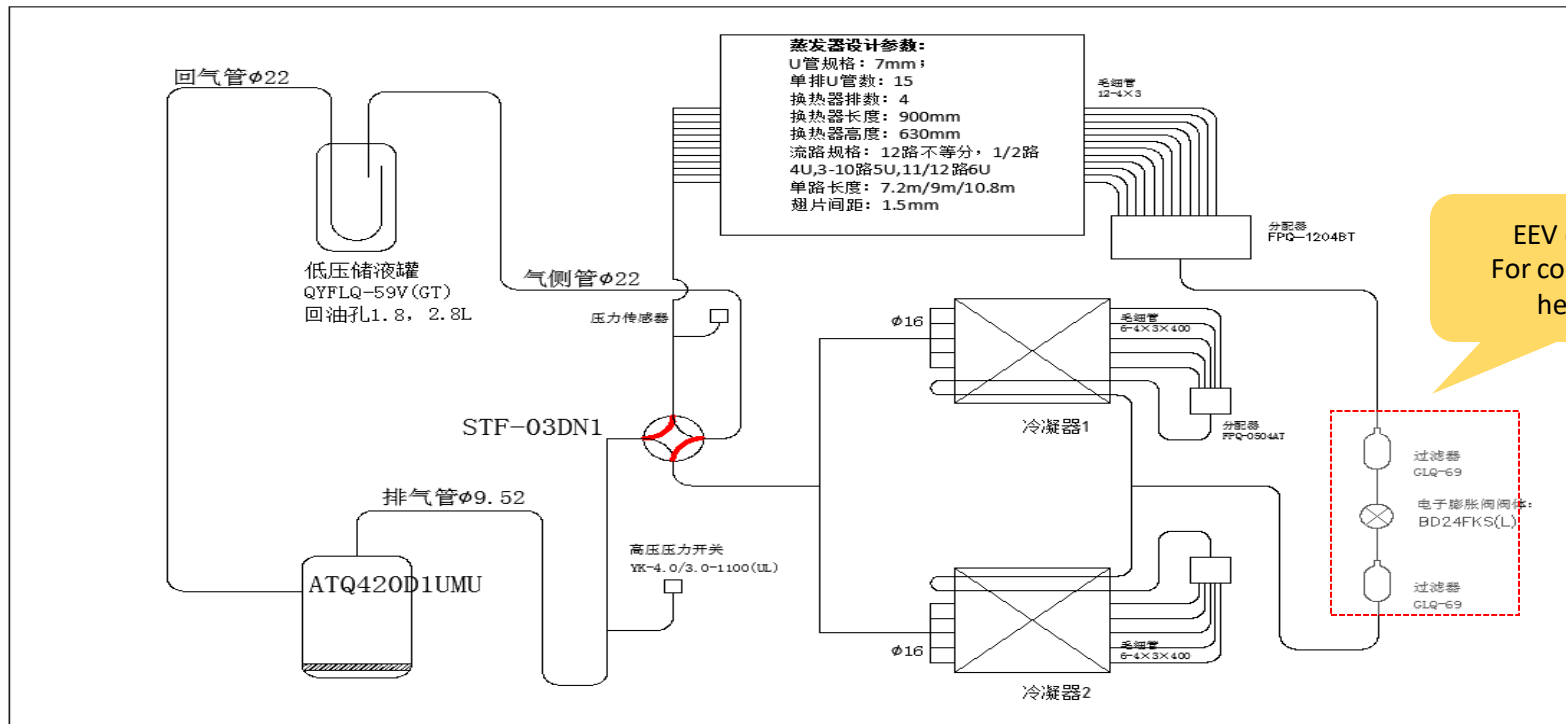

EEV control
For cooling and
heating

Specification Table

Capacity	ARI net capacity (Btu)	57000
	EER	12.5
	SEER	19
	Nominal CFM	1750
	System power (kW)	4.56
	Refrigerant type	R410a
	Refrigerant charge (lb-oz)	12-9
	ARI HEATING PERFORMANCE	
	47°F Capacity rating (Btu)	57000
	System power (kW)	4.5
	17°F Capacity rating (Btu)	41500
	System power (kW)	
HSPF (BTU/Watts-hr.)	9	
DIMENSIONS (Inches)	Length	51-9/16
	Width	44-13/16
	Height	52
Weight	OPERATING WT. (lbs)	562
COMPRESSORS	Type	Rotary
	Quantity	1
CONDENSER COIL DATA	Face area (Sq. Ft)	20.17
	Rows	3
	Fins per inch	17
	Tube diameter(inch)	9/32
	Circuitry type	interlaced

EVAPORATOR COIL DATA	Face area (Sq. Ft)	6.1	
	Rows	4	
	Fins per inch	17	
	Tube diameter(inch)	9/32	
Refrigerant control	Circuitry type	interlaced	
CONDENSER FAN DATA	Refrigerant control	EEV	
	CONDENSER FAN DATA	Fan diameter (inch)	25-3/5
		Type	Prop
		Drive type	Direct
		No. speeds	10
		Number of motors	1
		Motor HP each	1/3
		RPM	200~880
Nominal total CFM		4100	
DIRECT DRIVE EVAP FAN DATA	Quantity	1	
	Fan Size (Inch)	11×10-5/8	
	Type	Centrifugal	
	No. speeds	5	
	Motor HP each	3/4	
	RPM	1075	
Electrical Data	Motor frame size	48	
	Voltage-Phase-Hz	208/230-1-60	
	Minimum Circuit Amp	41.9	
	Max. Overcurrent Protection	60	
Operating Range	Min / Max Volts	173 / 269	
	Cooling	23°F-125.6°F	
	Heating	-4°F-86°F	

Thank You